

Catalog Number	
Project Notes	

Attain LED Panel

LED PANEL

Features & Functionality

- Purpose** 2'x2' T-bar retrofit LED panel for indoor IP20 projects.
- Material** Aluminum body with polycarbonate lens
- Finish** Available in White or Silver trim
- Mounting** Standard suspended T-Bar retrofit mount, recessed surface mount or suspended with cable kit
- Color Temp.** 3500°K, 3700°K, 4000°K and 5000°K.
- Beam Spread** 120° beam angle, integral diffuser lens for no points of light
- Output** 2'x2' model: up to 4,320 Lumens
- Dimming** 0-10V, compatible with most dimming systems
- Lifespan** 50,000 hours
- Warranty** 5-year warranty



Lumen Information

SERIES	LUMENS	WATTAGE	EFFICACY
22	3,000	25	120Lm/W
22	3,600	30	120Lm/W
22	4,320	36	120Lm/W



Product Selection Guide

Example: AT-PN-22-36-40-A

PRODUCT	SERIES	WATTAGE	COLOR TEMP	VOLTAGE	COLOR
AT-PN – Attain LED Panel	22 – 2'x2' Square	25 – 25W	35 – 3500°K	A – 100-277VAC	W – White S – Silver
		30 – 30W	37 – 3700°K		
		36 – 36W	40 – 4000°K		
		50 – 5000°K			

Cable Suspension Kit available



Dimensional Information

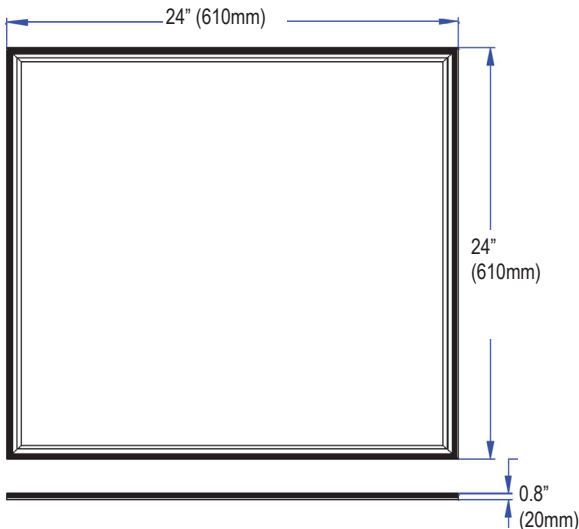

Attain LED Panel

PHOTOMETRY

2'x2' LED Panel AT-PN-22-XX

